

TRITON[®] TL-2 BARRIER

EASY TO DEPLOY STEEL REINFORCED PORTABLE BARRIER



OVERVIEW

The Triton Barrier[®] is a highly portable, water-filled barrier that is ideal for use where time and space are limited. It consists of a number of interlocking, 2 m (6.5 ft) barrier sections made of polyethylene plastic and an internal steel framework.

The Triton Barrier's performance exceeds NCHRP TL-2, 70 km/h (45 mph). The FHWA has issued a letter accepting that the Triton Barrier's performance exceeds NCHRP 350, Test Level 2 criteria and can be considered for 100 km/h (62 mph) applications at angles up to 15 degrees for passenger vehicles and lightweight pickup trucks.

CERTIFIED AS OWN END TREATMENT

The Triton Barrier is certified as its own end treatment, saving deployment time and hardware expenses. The last ten sections of Triton Barrier, when oriented properly in relation to traffic and according to the end treatment instructions provided by Energy Absorption Systems, serve as the crashworthy end treatment for this barrier system. Contact Energy Absorption Systems for details.

FEATURES AND BENEFITS

- ▶ Provides positive, crashworthy protection for workers and equipment
- ▶ Absorbs collision energy and redirects errant vehicles — reduces severity of impact for motorists.
- ▶ Fast deployment — 183 m (600 feet) per hour with just three workers.
- ▶ Modular design allows use in varied lengths for both straight and curved applications.
- ▶ No cranes or heavy equipment required for deployment.
- ▶ Certified as its own end treatment.
- ▶ Transition hardware available for attachment to guardrail or concrete barrier.
- ▶ Factory installed internal steel framework — no additional assembly required.
- ▶ Effective in all weather conditions, even when frozen solid.



Steel reinforced, water-filled barrier sections absorb collision energy and redirect vehicles away from work crews.

SAVING LIVES BY DESIGN



ENERGY ABSORPTION
SYSTEMS, INC.

WWW.ENERGYABSORPTION.COM

EASY DEPLOYMENT & REMOVAL

The Triton Barrier, at its 65 kg (140 lb) empty weight, can be easily unloaded and positioned without cranes or heavy equipment. In fact, three workers can deploy over 183 m (600 ft) in just one hour! Deployment involves three simple steps: unload; position and pin; and fill with water using a water truck.



Unload (No cranes needed)



Position and pin.



Fill using a water truck.

SPECIFICATIONS

Length	2 m	(78")
Height	800 mm	(32")
Width	500 mm	(21")
Weight Empty	65 kg	(140 lb)
Weight With Water	610 kg	(1,350 lb)
Water Ballast	550 liters	(145 gallons)

- 1 FILL LEVEL INDICATOR
- 2 STEEL PIN
- 3 FACTORY INSTALLED TENSION CABLE
- 4 GATE VALVE DRAIN
- 5 FORKLIFT PORTS
- 6 FILL HOLE CAP
- 7 2 M (6.5 FT) STEEL REINFORCED BARRIER SECTION

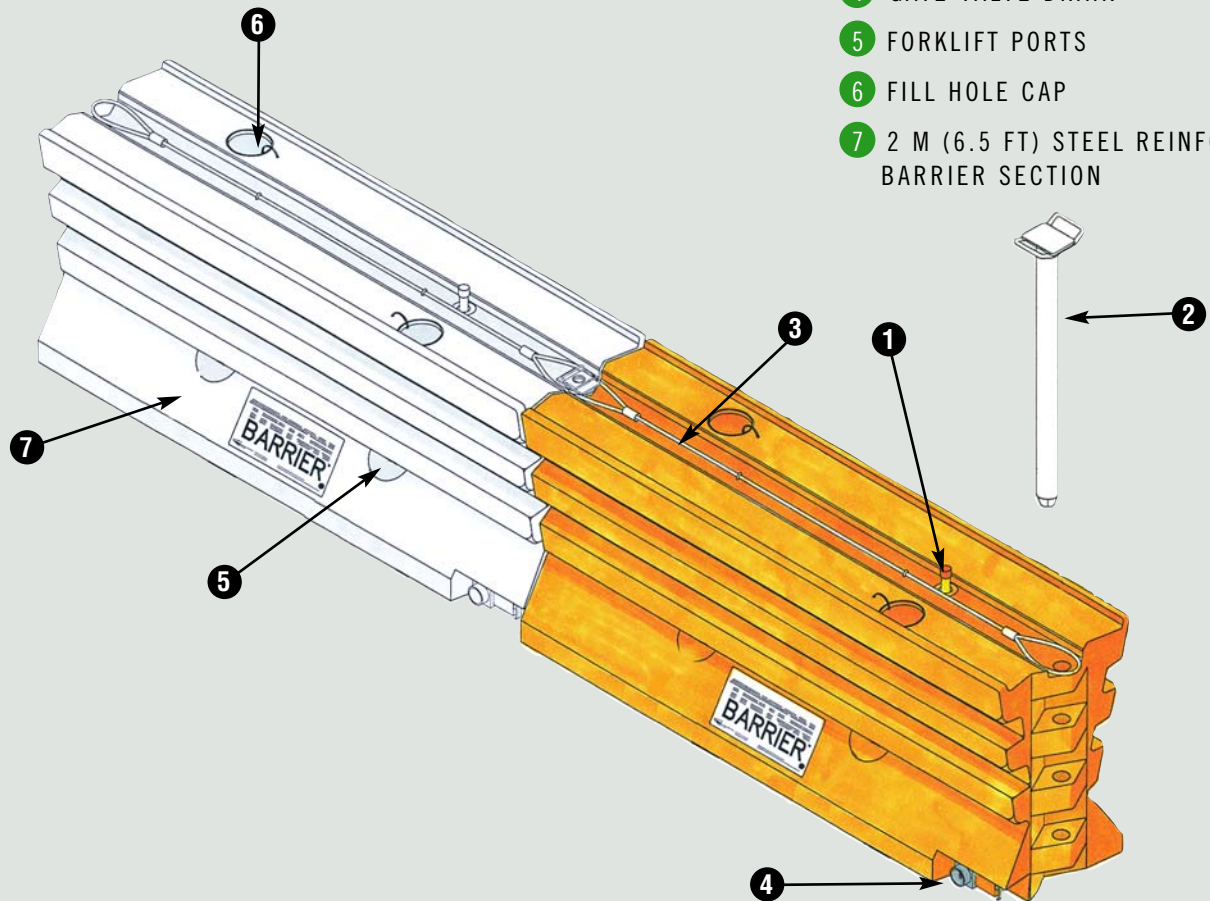

WWW.QUIXTRANS.COM



35 East Wacker Drive • Chicago, IL 60601
Tel: (312) 467-6750 • Fax: (312) 467-9625
www.energyabsorption.com

SAVING LIVES BY DESIGN



Distributed By:
Enterprise Flasher Company
(302)99-0856
Toll Free: (866)332-7238

General specifications for the Triton Barrier are subject to change without notice to reflect improvements and upgrades. Additional information is available in the Product Manual for this system. Contact Energy Absorption Systems for details.