

# TRITON<sup>®</sup> TL-3 BARRIER

## EASY TO DEPLOY STEEL REINFORCED PORTABLE BARRIER



### OVERVIEW

The Triton Barrier<sup>®</sup> TL-3 System provides an improved and more permanent method for upgrading existing Triton Barriers to NCHRP 350, Test Level 3. The Triton TL-3 allows users to “forget the kit,” and features a new pedestal system that uses only a screwdriver and steel strap to easily attach to the existing barrier.

After stacking the Triton Barrier on top of two new TL-3 pedestals, a mild strength steel band straps each pedestal to the barrier, creating a single, more permanent unit. Once assembled, the new Triton TL-3 creates positive, crashworthy protection up to 100 km/h (62 mph) that will help to prevent penetration into work areas. With the new easy-to-attach pedestals, Triton Barrier's center of gravity automatically adjusts to provide high-speed, NCHRP 350, TL-3 performance. As a portable barrier, the Triton TL-3 transports easily from site to site for fast deployment without the use of cranes or heavy equipment.

### CERTIFIED AS OWN END TREATMENT

The Triton Barrier TL-3 end treatment saves deployment time and hardware expenses. The last twenty sections of Triton Barrier, when oriented properly in relation to traffic and according to the end treatment instructions provided by Energy Absorption Systems, can serve as the crashworthy end treatment.

### FEATURES AND BENEFITS

- ▶ Steel-reinforced, water filled barriers absorb impact energy and safely redirects errant vehicles
- ▶ Positive, crashworthy protection up to 100 km/h (62 mph) — helps to prevent penetration into work areas.
- ▶ New TL-3 pedestals easily attach for a more permanent bond with existing Triton Barriers
- ▶ Fast and easy deployment
- ▶ Effective in all weather conditions — ideal for workzones

Steel reinforced, water-filled barrier sections absorb collision energy and redirect vehicles away from work crews.



### SAVING LIVES BY DESIGN



**ENERGY ABSORPTION**  
SYSTEMS, INC.

[WWW.ENERGYABSORPTION.COM](http://WWW.ENERGYABSORPTION.COM)

## TRITON TL-3 EASY AS 1-2-3!

The Triton Barrier, at its 65 kg (140 lb) empty weight, can be easily unloaded and positioned without cranes or heavy equipment. In fact, three workers can deploy over 183 m (600 ft) in just one hour! Deployment involves three simple steps: unload; position and pin; and fill with water using a water truck.



Place a Triton Barrier section on top of two TL-3 pedestals, directly aligned with the barrier's forklift ports. Since they're lightweight, no special equipment is required.



Attach the pedestals to the Triton Barrier section by placing the steel bands through the forklift ports and the slots in the pedestals.



Once all sections are in position with their pedestals, simply tighten down firmly with a screwdriver.

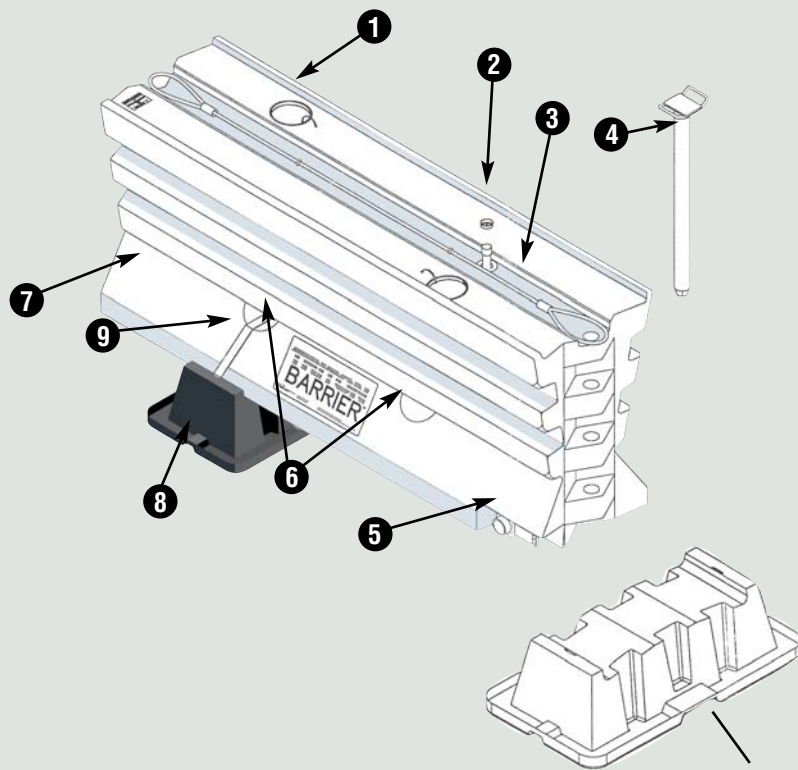

The Triton Barrier Pedestal

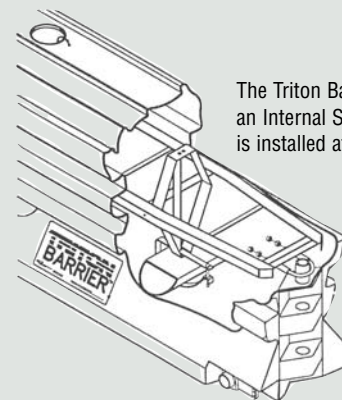

The Triton Barrier features an Internal Steel Frame which is installed at the factory.

## SPECIFICATIONS

Length	2 m (78")
Height	0.8 m (32")
Width	0.5 m (21")
Weight Empty	65 kg (140 lb)
Weight With Water	610 kg (1,350 lb)
Water Ballast	550 liters (145 gallons)

- 1 FILL HOLE CAP
- 2 FILL LEVEL INDICATOR
- 3 FACTORY INSTALLED TENSION CABLE
- 4 CONNECTING PIN
- 5 GATE VALVE DRAIN
- 6 FORKLIFT PORTS
- 7 2 M (6.5 FT) STEEL REINFORCED BARRIER SECTION
- 8 TL-3 PEDESTAL
- 9 TL-3 MOUNTING STRAPS



WWW.QUIXTRANS.COM



35 East Wacker Drive • Chicago, IL 60601  
Tel: (312) 467-6750 • Fax: (312) 467-9625  
www.energyabsorption.com

## SAVING LIVES BY DESIGN



Distributed By:  
**Enterprise Flasher Company**  
(302)99-0856  
Toll Free: (866)332-7238

General specifications for the Triton Barrier are subject to change without notice to reflect improvements and upgrades. Additional information is available in the Product Manual for this system. Contact Energy Absorption Systems for details.